

American DJ®

FUSION 250 SCAN



User Instructions

Rev. 10/09

Fusion Scan 250™

Introduction

Introduction: Congratulations and thank you for purchasing the Fusion Scan 250™ by American DJ®, one of the finest pieces of its kind on the market today! The Fusion Scan 250™ is an excellent, light weight, intelligent fixture. Due to its physical specifications, it's a great piece for mobile DJ's, roller rinks, small clubs, bars, and bowling centers. When used in multiples of two or more, these units create an effect that rivals that of units that can cost up to three times the price. The Fusion Scan 250™ was designed to run in a Master/Slave mode but can be used with any universal DMX-512 controller.

Customer Support: American DJ® provides a toll free customer support line, to provide set-up and installation help and to answer any question should you encounter problems during your set up or initial operation. You may also visit us on the web at www.americandj.com for any comments or suggestions. Toll free customer service hours are Monday through Friday 9:00 a.m. to 5:30 p.m. Pacific Standard Time.

Voice: (800) 322-6337

Fax: (323) 582-2941

E-mail: support@americandj.com

To purchase parts online visit <http://parts.americandj.com>

Warning! To prevent or reduce the risk of electrical shock or fire, do not expose this unit to rain or moisture.

Caution! There are no user serviceable parts inside this unit. Do not attempt any repairs yourself, doing so will void your manufacturer's warranty. In the unlikely event your unit may require service please contact American DJ® customer support.

Please recycle the shipping carton when ever possible.

Improvements and changes in specifications and design to this manual and unit may be made at any time without prior notice.

HALOGEN LAMP WARNING!

This fixture is fitted with a halogen lamp which is highly susceptible to damage if improperly handled. Never touch the lamp with your bare fingers as the oil from your hands will shorten the lamp life. Never install, mount, or place this fixture in areas prone to heavy vibration. Also, never move the fixture until the lamp has had ample time to cool. Remember, lamps are not covered under warranty conditions.



- Do not spill water or other liquids into or on to your unit.
- Be sure that the local power outlet match that of the required volt age for your unit.
- Do not attempt to operate this unit if the power cord has been frayed or broken. Please route your power cord out of the way of foot traffic.
- Do not attempt to remove or break off the ground prong from the electrical cord. This prong is used to reduce the risk of electrical shock and fire in case of an internal short.
- Disconnect from main power before making any type of connection.
- Do not remove the top cover under any conditions. There are no user serviceable parts inside.
- Never plug this unit in to a dimmer pack
- Always be sure to mount this unit in an area that will allow proper ventilation. Allow about 6" (15cm) between this device and a wall.
- Do not attempt to operate this unit, if it becomes damaged in any way.
- Never operate this unit when it's cover is removed.
- To reduce the risk of electrical shock or fire, do not expose this unit rain or moisture
- This unit is intended for indoor use only, use of this product out doors voids all warranties.
- During long periods of non-use, disconnect the unit's main power.
- Always mount this unit in safe and stable matter.
- Power Cord Protection - Power cords should be routed so they are not likely to be walked on or pinched by items placed upon or against them, paying particular attention to cords at plugs, convenience receptacles, and the point where they exit from the unit.
- Cleaning - Follow the directions on page 14.
- Heat -The unit should be situated away from heat sources such as radiators, heat registers, stoves, or other appliances (including amplifiers) that produce heat.

- The fixture should be serviced by qualified service personnel when:
 - A. The power-supply cord or the plug has been damaged.
 - B. Objects have fallen, or liquid has been spilled into the appliance.
 - C. The appliance has been exposed to rain or water.
 - D. The fixture does not appear to operate normally or exhibits a marked change in performance.

The Fusion Scan 250™ features a bright 250 watt halogen bulb with a separate gobo and color wheel and a green laser effect. The color wheel features seven brilliant colors plus white and the gobo wheel features 10 gobos plus a large spot. This fixture incorporates the use of high quality stepper motors for a more accurate mirror movement. Mirror movement allows for a full 90 degree tilt (vertical) and a 45 degree pan (horizontal). An internal built in microphone allows the fixtures to run in Stand Alone mode so there is no need for an external controller. The Fusion Scan 250™ may also be set-up to run in a Master-Slave mode when used in multiples, up to four units. When used in the Master-Slave mode, the unit will chase to several internal programs. The Fusion Scan 250™ can also be controlled via a standard DMX controller such as the Elation® Show Designer,™ or the Elation® DMX Operator,™ giving the user independent control over the gobo and color wheel as well as the mirrors pan and tilt movements.

Note: The built in programs in the Fusion Scan 250™ are so good you may never need a DMX controller.

- ZB-ELC10 24V/250W
- DMX-512 Compatible.
- Stepper motors for smooth movements.
- 7 colors plus white.
- 10 Gobos plus spot.
- Green Laser
- Gobo Shake
- Master/Slave Operation
- Sound Active.
- Optional MINI/C controller, for blackout control.
- Optional Wireless MINI/C controller, for blackout control.

NON-INTERLOCKED HOUSING WARNING

The Fusion Scan 250™ contains high power laser devices internally. **Do not** open the laser housing, due to the potential exposure to unsafe levels of laser radiation. The laser power levels, if the unit is opened, can cause instant blindness, skin burns and fires.

**STOP AND READ ALL LASER SAFETY DATA
OPERATION INSTRUCTIONS AND LASER SAFETY**

The light source emitted from this product can potentially cause eye injury if not set up and used properly. The light source emitted from a laser is very different from any other light sources with which you may be aware of. Laser light is thousands of times more concentrated than any light from any other kind of light source. This concentration of light can cause instant eye injuries, primarily by burning the retina (the back of your eyeball containing cells that are sensitive to light). Even if you cannot feel “heat” from a laser beam, it can still potentially injure or blind you or your audience. Even very small amounts of laser beam light are potentially hazardous even at long distances. Laser eye injuries can be sustained faster than you can blink.

Do not think that because this laser splits the laser beam into hundreds of beams and that the laser beam is scanned out in high speed, that an individual laser beam is safe for eye exposure. This laser uses dozens of milliwatts of laser power (Class 3B levels internally) before it splits into multiple beams (Class 3R levels). Many of the individual beams are potentially hazardous to the eyes.

Do not think that because the laser light is moving, it is safe. This is not true. Nor, do the laser beams always move. Since eye injuries can occur instantly, it is critical to prevent even the smallest possibility of any direct eye exposure. In the laser safety regulation, it is not legal to aim Class 3R lasers in areas which people can get exposed. This is true even if it is aimed below people’s faces, such as on a dance floor.

Do not operate the laser without first reading and understanding all safety and technical data in this manual.

Always set up and install all laser effects so that all laser light is at least 3 meters (9.8 feet) above the floor on which people can stand.

After setting up, and before public use, test laser to ensure proper function. Do not use if any defect is detected. Do not use if laser emits only one or two laser beams rather than dozens/hundreds, as this could indicate damage to the diffraction grating optic, and could allow emission of higher laser levels above Class 3R.

Do not point lasers at people or animals. Never look into the laser aperture or laser beams.

Do not point lasers in areas in which people can potentially get exposed, such as uncontrolled balconies, etc.

Do not point lasers at highly reflective surfaces, such as windows, mirrors and shiny metal. Even laser reflections can be hazardous.

Never point a laser at aircraft, this is a federal offense.

Never point un-terminated laser beams into the sky.

Do not expose the output optic (aperture) to cleaning chemicals.

Do not use laser if the laser appears to be emitting only one or two beams.

Do not use the laser if the housing is damaged, the housing is open, or if the optics appear damaged in any way.

Never open the laser housing. The high laser power levels inside of the protective housing can start fires, burn skin and will cause instant eye injury.

Never leave this device running unattended.

The operation of a class 3R laser show is only allowed if the show is controlled by a skilled and well- trained operator, familiar with the data included in this manual.

The legal requirements for using laser entertainment products vary from country to country. The user is responsible for the legal requirements at the location/country of use.

Always use proper lighting safety cables when hanging lights and effects overhead.

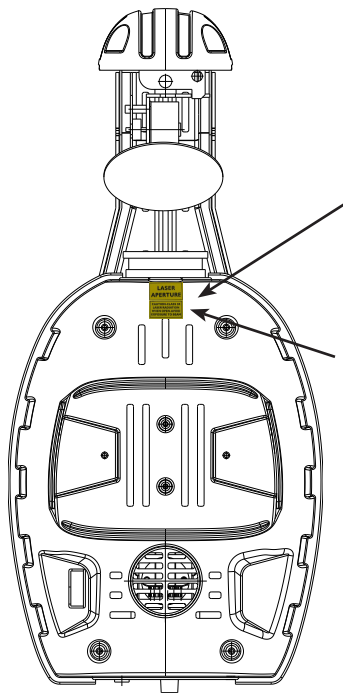

LASER APERTURE

CAUTION-CLASS 3R LASER RADIATION WHEN OPEN.AVOID EXPOSURE TO BEAM

Number 10, alley 41, lane 116
Chun Ying St., ShuLin City Taipei Hsien,
Taiwan R.O.C

Complies with performance standards
For laser products with the exception of
deviation pursuant to Laser Notice
Number 50, date July 26, 2001

**LASER RADIATION
AVOID DIRECT EYE EXPOSURE**

CLASS 3R LASER PRODUCT
5.0mW max CW Diode 532nm
IEC/EN 60825-1, ed 1.2

**CAUTION
CLASS 3R LASER RADIATION WHEN
OPEN AVOID DIRECT EYE EXPOSURE**

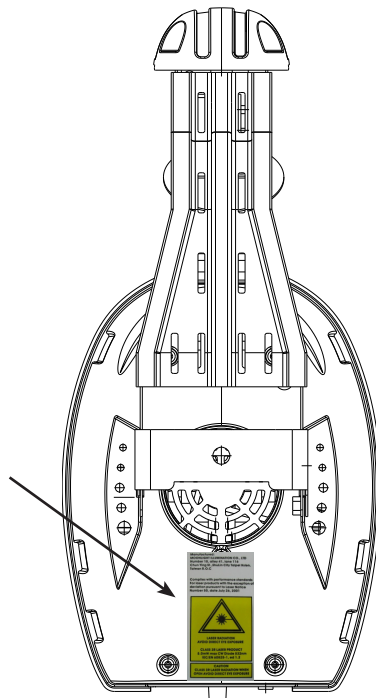

Power Supply: Before plugging your unit in, be sure the source voltage in your area matches the required voltage for your American DJ® Fusion Scan 250.™ The American DJ® Fusion Scan 250™ is available in a 120v and 220v version. Because line voltage may vary from venue to venue, you should be sure your unit voltage matches the wall outlet voltage before attempting to operate you fixture. Also be sure the power cable matches the voltage and current requirements of the unit.

DMX-512: *DMX is short for Digital Multiplex. This is a universal protocol used by most lighting and controller manufactures as a form of communication between intelligent fixtures and controllers. A DMX controller sends DMX data instructions from the controller to the fixture. DMX data is sent as serial data that travels from fixture to fixture via the DATA “IN” and DATA “OUT” XLR terminals located on all DMX fixtures (most controllers only have a DATA “OUT” terminal).*

DMX Linking: DMX is a language allowing all makes and models of different manufactures to be linked together and operate from a single controller, as long as all fixtures and the controller are DMX compliant. *To ensure proper DMX data transmission, when using several DMX fixtures try to use the shortest cable path possible. The order in which fixtures are connected in a DMX line does not influence the DMX addressing. For example; a fixture assigned a DMX address of 1 may be placed anywhere in a DMX line, at the beginning, at the end, or anywhere in the middle. Therefore, the first fixture controlled by the controller could be the last fixture in the chain. When a fixture is assigned a DMX address of 1, the DMX controller knows to send DATA assigned to address 1 to that unit, no matter where it is located in the DMX chain.*

Data Cable (DMX Cable) Requirements (For DMX and Master/Slave Operation): The Fusion Scan 250™ can be controlled via DMX-512 protocol. The Fusion Scan 250™ is a five channel DMX unit. The DMX address is set using the dipswitches on the front panel of the unit. Your unit and your DMX controller require a standard 3-pin XLR connector for data input and data output (Figure 1). If you are making your own cables, be sure to use standard two



Figure 1

conductor shielded cable (This cable may be purchased at almost all professional sound and lighting stores). Your cables should be made with a male and female XLR connector on either end of the cable. Also remember that DMX cable must be daisy chained and cannot be split.

Notice: Be sure to follow figures two and three when making your own cables. Do not use the ground lug on the XLR connector. Do not connect the cable’s shield conductor to the ground lug or allow the shield conductor to come in contact with the XLR’s outer casing. Grounding the shield could cause a short circuit and erratic behavior.

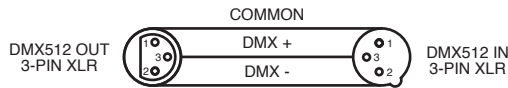

Figure 2

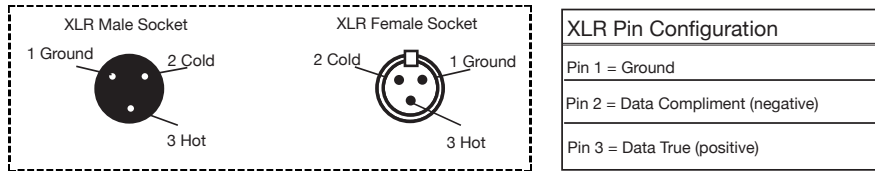

Figure 3

Special Note: Line Termination. When longer runs of cable are used, you may need to use a terminator on the last unit to avoid erratic behavior. A terminator is a 90-120 ohm 1/4 watt resistor which is connected between pins 2 and 3 of a male XLR connector (DATA + and DATA -). This unit is inserted in the female XLR connector of the last unit in your daisy chain to terminate the line. Using a cable terminator (ADJ part number Z-DMX/T) will decrease the possibilities of erratic behavior.



Termination reduces signal errors and avoids signal transmission problems and interference. It is always advisable to connect a DMX terminal. (Resistance 120 Ohm 1/4 W) between PIN 2 (DMX-) and PIN 3 (DMX +) of the last fixture.

Figure 4

5-Pin XLR DMX Connectors. Some manufactures use 5-pin XLR connectors for DATA transmission in place of 3-pin. 5-pin XLR fixtures may be implemented in a 3-pin XLR DMX line. When inserting standard 5-pin XLR connectors in to a 3-pin line a cable adaptor must be used, these adaptors are readily available at most electric stores. The chart below details a proper cable conversion.

3-Pin XLR to 5-Pin XLR Conversion		
Conductor	3-Pin XLR Female (Out)	5-Pin XLR Male (In)
Ground/Shield	Pin 1	Pin 1
Data Compliment (- signal)	Pin 2	Pin 2
Data True (+ signal)	Pin 3	Pin 3
Not Used		Pin 4 - Do Not Use
Not Used		Pin 5 - Do Not Use

CAUTION IMPORTANT! When installing this projector, make sure that it is mounted in a manner that prevents the audience from looking directly into the beam, and the beam from striking the audience.

For best results use fog or special effects smoke to enhance the beams projections. The Fusion Scan 250™ comes with a protective transportation cover. Be sure to remove it before attempting any operation!

Stand Alone, Sound Active Mode:

1. To operate as a stand alone, sound active unit, set dipswitch #10 into the 'On' position.
2. Adjust the sensitivity knob on the bottom of the unit so the unit will react to sound.
3. The Fusion Scan 250™ will now react to the bass sound of music via the internal microphone.

Master-Slave Operation (Sound Active):

This function will allow you to link units together to run a master/slave configuration. The units will be sound activated. In Master-Slave operation one unit will act as the controlling unit and the others will react to the controlling units programs. Any unit can act as a Master or as a Slave.

1. Daisy chain your units via the XLR connector on the bottom of the units.
2. Use standard XLR microphone cables to link your units together. Remember that the Male XLR connector is the input and the Female XLR connector is the output.
3. The first unit in the chain (master) will use the female XLR connector only - The last unit in the chain will use the male XLR connector only.
4. Please follow chart on page 13 for dipswitch settings, or to run a synchronized light show set all the dipswitches on the slave fixtures to the 'off' position, and on the master unit set dipswitch #10 to the "on" position. All fixtures will now run in the same exact pattern.

Note: Only one fixture may use the master units dipswitch settings.

5. After all the units settings have been set and are plugged in, adjust the sensitivity knob on the bottom of the master unit to

make them react to sound.

7. You can also use the optional MINI/C Remote Control. If you want to use the optional remote control, connect the MINI/C controller to the first fixture in the line (master).

Note: The remote control only operates in Stand-Alone and Master/Slave modes. If the remote is connected in DMX mode it will not function. If the units do not receive an active DMX signal, the units will automatically react to sound in the Master/Slave mode.

DMX Mode:

This fixture will react with DMX operation. For best results use only one motor function for each scene (or step), when programming scenes into a DMX controller. This will give you faster mirror and faster gobo/color changes. For Example:

- A. With the DMX controller move the mirror up then program the step.
 - B. Move the mirror down then program that step.
 - C. Change the gobo/color wheel then program that step.
 - D. Continue this pattern to achieve best results.
1. Operating through a DMX controller gives the user freedom to create his/her own programs tailored to their own individual needs. This function also allows you to use your fixtures as spots.
 2. This operation will allow you to control each individual fixtures traits with a standard DMX 512 controller such as the Elation® Show Designer™ or the Elation® DMX Operator.™
 3. The Fusion Scan 250™ uses five DMX channels to operate; Channel 1 is Pan, channel 2 is Tilt, channel 3 is Color, channel 4 Gobos, and channel 5 controls the Green Laser.
 4. To run your fixture in DMX mode, plug in the fixture via the XLR connections to any standard DMX controller. Set dipswitch #1 to the on position - Follow the set-up specifications that come with the controller.

Fusion Scan 250™

Optional Remote

The MINI/C controller may be purchased separately allowing you to control the main unit, and any others connected to it, while it is in stand alone mode. You can set the unit to blackout. If you have more than one unit, make sure the remote control is plugged into the first unit in the daisy chain. The remote control will not have any effect if the unit is in DMX mode. When the unit is in blackout mode, the light will come on next to the blackout button.

The Fusion Scan 250™ may be controlled by a wide range of controllers; ie. Show Designer™, DMX Operator™, Scene Setter™ or by the DJ MINI/C basic controller.

MINI/C features:



Fusion Scan 250™

Lamp Replacement

Lamp Replacement: Caution! Never open the unit when in use. Always disconnect the main power before attempting to replace the lamp.

1. Be sure to follow the proper procedures when handling halogen bulbs.
2. Lamp replacement has been made simple by incorporating the use of a removable lamp tray and thumb screws.
3. Loosen the thumb screw on rear cover.
4. Remove the tray.
5. Remove and replace the bulb.
6. Reassemble.

Remember to always replace with the exact same type lamp and fuse, unless otherwise specified by an authorized American DJ service technician.

Fusion Scan 250™

Focusing

1. To focus a Fusion Scan 250,™ it is best to first turn down the music sensitivity knob to its minimum position.
2. Loosen the thumb screw on the front of the unit that hold the lens in place.
3. Adjust the focus by manually moving the lens up and down.
4. Tighten the thumb screw after you achieve your desired focus.

Fusion Scan 250™

Product Registration

The Fusion Scan 250™ carries a one year (365 days) limited warranty. We recommend you fill out the enclosed warranty card to validate your purchase. All returned service items whether under warranty or not, must be freight pre-paid and accompany a return authorization (R.A.) number. If the unit is under warranty, you must provide a copy of your proof of purchase invoice. Please contact American DJ® customer support for a R.A. number.

Listed below are a few common problems the user may encounter, with solutions.

No light from the unit;

1. Check the breaker in the back panel.
2. Check if lamp is lit. The user should be able to see some light escape through the fan. If power is present but the lamp is not lit, lamp may need to be replaced.

Note: The unit has been designed to shut the lamp down after 60 seconds of inactivity. This is a way of extending lamp life, be assured this is not the problem with the fixture.

Unit not responding to DMX;

1. Check the dipswitch settings.
2. Check that all cables are connected to the right connectors; it does matter which way the inputs and outputs are connected.
3. If it is a bad connection, the Green LED may flash when cables are wiggled (but remember it may also be the unit sensing audio!)
4. If DMX connectors are fairly short, ordinary microphone cables may be used. For longer runs, this may cause data transmission problems (which will show up as random or incorrect movements) for best result, use proper balanced data transmission cable.

Unit does not respond to sound;

1. Be sure the audio sensitivity knob is turned in the full clockwise position (maximum sensitivity).

Unit blacks out in stand alone mode;

1. Some of the units' built-in patterns include special effects such as blackout sweeps.
2. Be sure the audio sensitivity knob is turned in the full clockwise position (maximum sensitivity).

If problems are not resolved; Contact your American DJ® customer support for possible service options.

Due to fog residue, smoke, and dust, cleaning the internal and external optical lenses must be carried out periodically to optimize light output.

1. Use normal glass cleaner and a soft cloth to wipe down the outside casing.
2. Use a brush to wipe down the fan grill.
3. Clean the external optics with glass cleaner and a soft cloth every 20 days. Situation may vary. If used heavily in clubs with lots of fog, cleaning may be required more often.
4. Clean the internal optics with glass cleaner and a soft cloth every 30-60 days.
5. Always be sure to dry all parts completely before plugging the unit in.

Cleaning frequency depends on the environment in which the fixture operates (i.e. smoke, fog residue, dust, dew).

This unit is equipped with a built-in safety breaker. This breaker is designed to close the power circuit in the event of an internal short or power surge. This will reduce the risk of electrical shock or fire and protect the circuitry. To reset the breaker, push the breaker button in until you hear it "pop" back in to place. If the breaker continues to pop, stop using the unit and contact our customer support team, the unit may need to be returned for service.

Fusion Scan 250™

Master/Slave Settings

The following details the proper dipswitch setting for Master-Slave configuration.

Master/Slave Chart Program 1

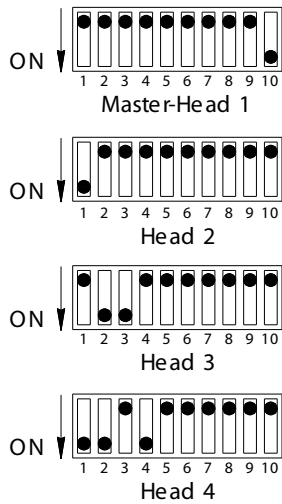

Master/Slave Chart Program 2

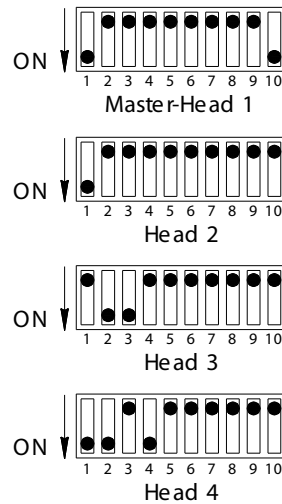

Fusion Scan 250™

Gobo Layout

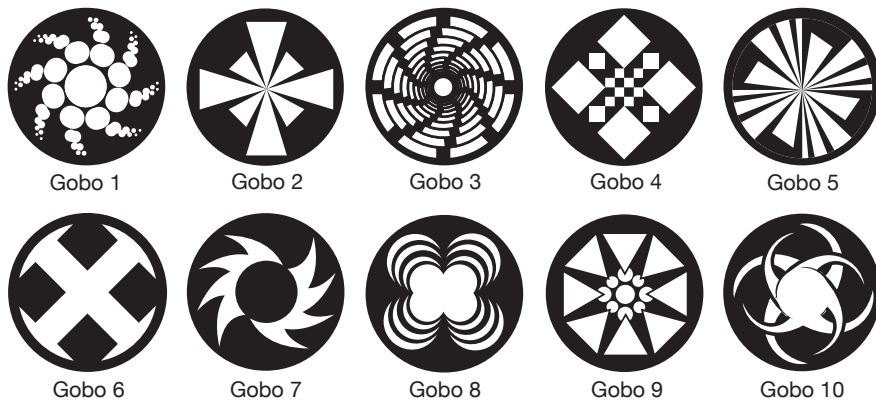

Fusion Scan 250™

DMX Traits

Channel	Value	Function
1	0 - 255	PAN
2	0 - 255	TILT
3	0 - 28 29 - 57 58 - 86 87 - 115 116 - 144 145 - 173 174 - 202 203 - 231 232 - 255	<u>COLORS</u> LAMP OFF WHITE RED BLUE GREEN YELLOW ORANGE PINK PURPLE
4	0 - 7 8 - 21 22 - 29 30 - 43 44 - 51 52 - 65 66 - 73 74 - 87 88 - 95 96 - 109 110 - 117 118 - 131 132 - 139 140 - 153 154 - 161 162 - 175 176 - 183 184 - 197 198 - 205 206 - 219 220 - 227 228 - 241 242 - 249 250 - 255	<u>GOBO</u> SPOT SPOT SHAKE GOBO 1 GOBO 1 SHAKE GOBO 2 GOBO 2 SHAKE GOBO 3 GOBO 3 SHAKE GOBO 4 GOBO 4 SHAKE GOBO 5 GOBO 5 SHAKE GOBO 6 GOBO 6 SHAKE GOBO 7 GOBO 7 SHAKE GOBO 8 GOBO 8 SHAKE GOBO 9 GOBO 9 SHAKE GOBO 10 GOBO 10 SHAKE BLACKOUT BLACKOUT SHAKE
5	0 - 127 128 - 255	<u>GREEN LASER</u> LASER OFF LASER ON

Fusion Scan 250™

Warranty

MANUFACTURER'S LIMITED WARRANTY

A. American DJ, Inc. hereby warrants, to the original purchaser, American DJ and American Audio products to be free of manufacturing defects in material and workmanship for a prescribed period from the date of purchase (see specific warranty period on reverse). This warranty shall be valid only if the product is purchased within the United States of America, including possessions and territories. It is the owner's responsibility to establish the date and place of purchase by acceptable evidence, at the time service is sought.

B. For warranty service you must obtain a Return Authorization number (RA#) before sending back the product. Contact American DJ, Inc. Service Department at 800-322-6337. Send the product only to the American DJ, Inc. factory. All shipping charges must be pre-paid. If the requested repairs or service (including parts replacement) are within the terms of this warranty, American DJ, Inc. will pay return shipping charges only to a designated point within the United States. If the entire instrument is sent, it must be shipped in its original package. No accessories should be shipped with the product. If any accessories are shipped with the product, American DJ, Inc. shall have no liability whatsoever for loss of or damage to any such accessories, nor for the safe return thereof.

C. This warranty is void if the serial number has been altered or removed; if the product is modified in any manner which American DJ, Inc. concludes, after inspection, affects the reliability of the product; if the product has been repaired or serviced by anyone other than the American DJ, Inc. factory unless prior written authorization was issued to purchaser by American DJ, Inc.; if the product is damaged because not properly maintained as set forth in the instruction manual.

D. This is not a service contract, and this warranty does not include maintenance, cleaning or periodic check-up. During the period specified above, American DJ, Inc. will replace defective parts at its expense with new or refurbished parts, and will absorb all expenses for warranty service and repair labor by reason of defects in material or workmanship. The sole responsibility of American DJ, Inc. under this warranty shall be limited to the repair of the product, or replacement thereof, including parts, at the sole discretion of American DJ. All products covered by this warranty were manufactured after January 1, 1990, and bear identifying marks to that effect.

E. American DJ, Inc. reserves the right to make changes in design and/or improvements upon its products without any obligation to include these changes in any products theretofore manufactured. No warranty, whether expressed or implied, is given or made with respect to any accessory supplied with products described above. Except to the extent prohibited by applicable law, all implied warranties made by American DJ, Inc. in connection with this product, including warranties of merchantability or fitness, are limited in duration to the warranty period set forth above. And no warranties, whether expressed or implied, including warranties of merchantability or fitness, shall apply to this product after said period has expired. The consumer's and/or Dealer's sole remedy shall be such repair or replacement as is expressly provided above; and under no circumstances shall American DJ, Inc. be liable for any loss or damage, direct or consequential, arising out of the use of, or inability to use, this product.

This warranty is the only written warranty applicable to American DJ and American Audio Products and supersedes all prior warranties and written descriptions of warranty terms and conditions heretofore published.

MANUFACTURER'S LIMITED WARRANTY PERIODS:

- All American Audio Products = 1-year (365 day) Limited Warranty (except V-Plus Series Amplifiers)
- All American Audio V-Plus Series Amplifiers = 3-year (1095 day) Limited Warranty
- American DJ Lighting and American DJ Branded Products = 1-year (365 day) Limited Warranty (Such as: Special Effect Lighting, Intelligent Lighting, UV lighting, Strobos, Fog Machines, Bubble Machines, Mirror Balls, Par Cans, Trussing, Lighting Stands etc. excluding Laser Products, lamps, and Star Tec Series)
- American DJ Laser Products and Star Tec Products = 90-Day Limited Warranty
- American DJ L.E.D. Products = 3-year (1095 day) Limited Warranty (excluding motors which have a 1-year (365 day Limited Warranty)

Specifications: Fusion Scan 250™

Weight:	11.4 Lbs.
Dimensions:	21" (L) x 9" (W) x 9.5" (H)
Lamp:	ZB-ELC 24v/250w
Laser:	4.9mW Green Diode
Breaker:	5 Amp
Voltage*:	120v/220v, 60Hz/50Hz
Gobos:	10 Plus Spot
Colors:	7 Plus White
Cooling:	Fan Cooled
Working Position:	Any Safe Position

* Operating voltage is preset at the factory.

Please Note: Specifications and improvements in the design of this unit and this manual are subject to change without any prior written notice.

American DJ®

American DJ World Headquarters:

6122 S. Eastern Ave. Los Angeles, CA 90040 USA

Tel: 323-582-2650 / Fax: 323-725-6100

Web: www.americandj.com / E-mail: info@americandj.com